

Technical information

Testing and Operating Pressures

Henrad Verona Range has been independently tested to ensure radiators perform to a maximum working pressure of 4.6 bar.

Connections

Henrad Verona has 2 x 15mm connections (BOE) as standard.

Paint Process

Two coat paint process, each Henrad radiator is subjected to a multi-stage cleaning and paint process.

The final powder coat is Traffic white (RAL A9016) which is stoved and cooled to give a perfect finish. All radiators are illustrated in Traffic white unless stated.

Water Treatment

Installation of the system should be properly flushed and fitted in accordance with the British Code of Practice for the Treatment of Water in Domestic Hot Water Central Heating Systems.

Warranty

Henrad Verona Range come with a 5 year manufacturer's warranty.

Henrad (UK) Limited, Marriott Road,
Mexborough, South Yorkshire S64 8BN.
Telephone: 0844 543 6200 Facsimile: 0844 543 6300

www.henrad.co.uk

Henrad Verona

Wall Mounting Information

All dimensions in mm.

Henrad Verona Plane

Henrad Verona Vertical

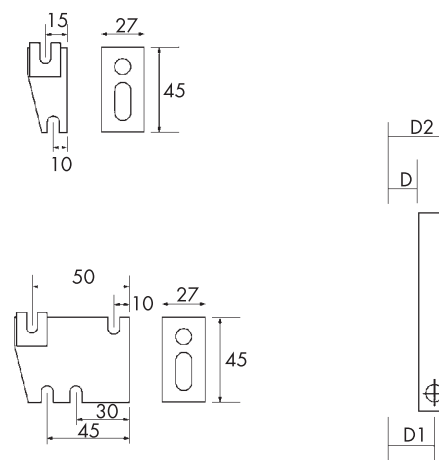

Type	From back of radiator to wall D	From wall to centre of connections D1	From front of radiator to wall D2
Verona Plane Single	9	44	69
Verona Plane Double	27	94	119
Verona Vertical	25	44	70

Henrad Verona Slimline

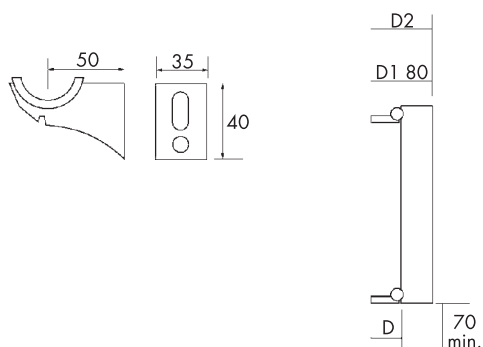

Type	Back face to finished wall D	From wall to centre of connections D1	From front of radiator to wall D2
Verona Slimline	35	50	130